

REVISION HISTORY			
REV.	DESCRIPTION	DATE	APPROVED
A	I.S.O. CERTIFIED	09/12/1999	KAH
B	REDRAWN w/o CHANGE	10/06/2006	KAH

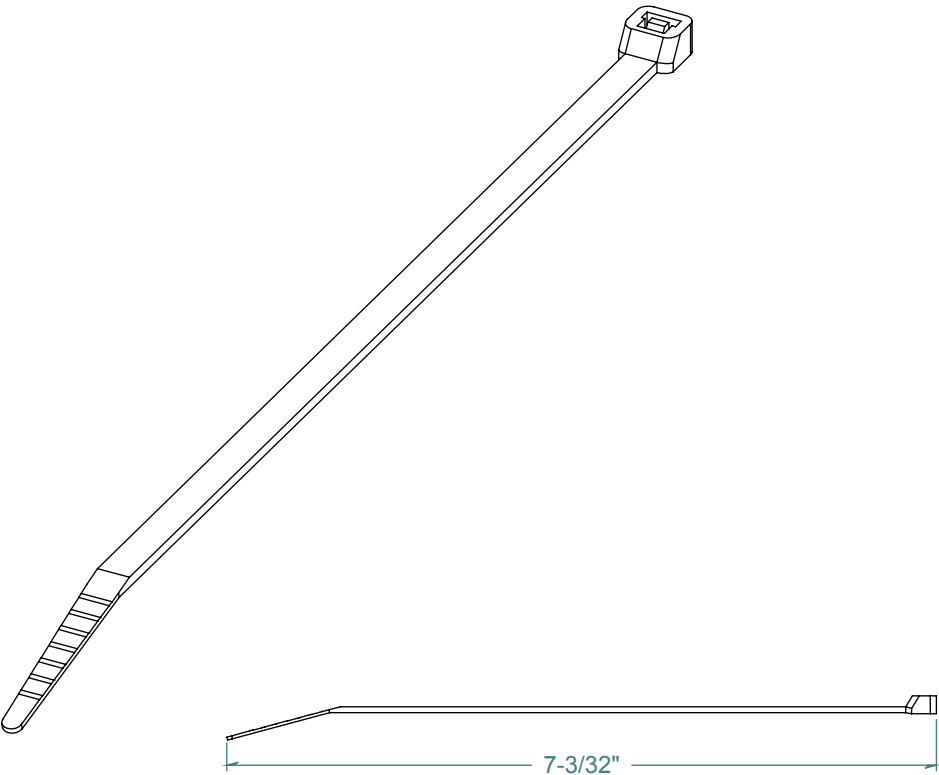
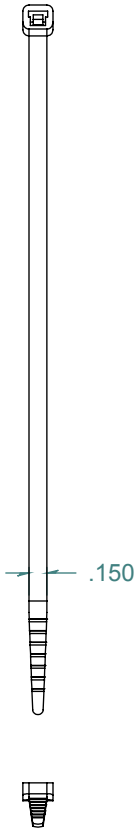

DIMENSIONS ARE IN INCHES UNLESS SPECIFIED. TOLERANCES ARE:
 FRACTIONS +/- .015
 2 PLACE DECIMAL +/- .010
 3 PLACE DECIMAL +/- .005
 ANGLES NOTED
 * Call-Out is reference only and may vary, minimally, beyond standard tolerances.

ARK-PLAS PRODUCTS, INC.

APDT06750
 7.1" BUNDLING TIE

MAXIMUM BUNDLING DIAMETER 1-1/2"

FREE SAMPLES ARE AVAILABLE FOR TESTING. CONTACT CUSTOMER SERVICE

MATERIAL:
NATURAL NYLON
 FINISH: Ark-Plas Standard
 (Unless Specified)

JOB #		PRINT ISSUE DATE: 10/06/06	
SIZE A	SCALE: 1:2	SHEET: 1 OF 1	REV. LEVEL B
DO NOT SCALE DRAWING		DRAWN BY: <i>KAH</i>	

PROPRIETARY AND CONFIDENTIAL
 THE INFORMATION CONTAINED IN THIS DRAWING IS THE SOLE PROPERTY OF ARK-PLAS PRODUCTS, INC. ANY REPRODUCTION IN PART OR AS A WHOLE WITHOUT THE WRITTEN PERMISSION OF ARK-PLAS PRODUCTS, INC. IS PROHIBITED.